



*543 North Neil Armstrong Road
Salt Lake City, Utah 84116-2887
(801) 363-2990 phone
(801) 537-1470 fax
www.hoyt.com*

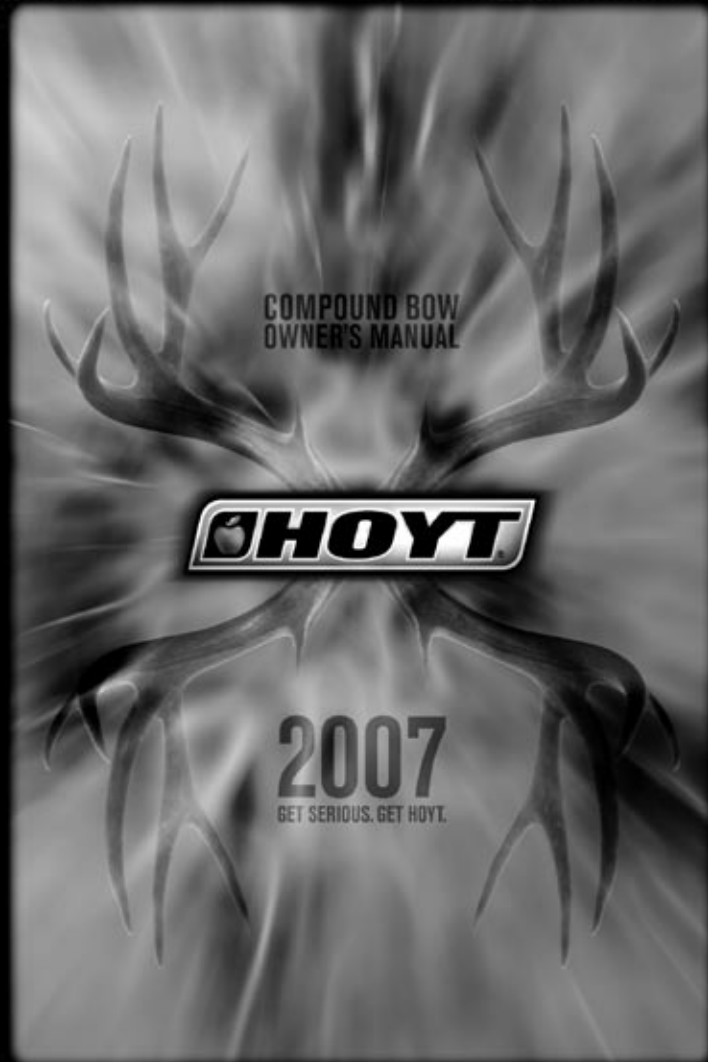

TABLE OF CONTENTS

Bow Owner's Personal Record	2
Compound Bow Terminology	3
Important Safety Information	4
Compound Bow Maintenance	
Strings and Cables	6
Eccentric Lubrication	7
Bow Press Use	7
Initial Compound Bow Setup	
Rest Selection	9
Nock Set Installation	10
Cable Guard Installation	11
Tiller Adjustment	12
Centershot	13
Arrow Fletch Clearance	14
Compound Bow Adjustment	
Draw Weight Adjustment	14
StealthShot Adjustment	15
Cam & 1/2 Draw Length Adjustment	15
Optimizing Cam & 1/2 Performance	16
Zephyr Cam & 1/2	18
Optimizing Zephyr Cam & 1/2 Performance	19
Optimizing Vector and C2 Cam & 1/2 Performance ..	20
Wheel & 1/2 Draw Length and Optimization	21
Wheel & 1/2 Optional Draw Stop	23
Versa Cam & 1/2 Draw Length Adjustment	23
Versa Cam & 1/2 Control Cable Removal	25
Locating Your Bow's Serial Number	26
Tuning Your Compound Bow	27
Compound Bow Warranty	27

INTRODUCTION

Welcome to the Hoyt family!

As a member of an elite team, you will be pleased to know that you have purchased the finest crafted, most dependable bow on the market. Only the finest components go into every Hoyt bow along with over 75 years of experience in bow technology and manufacturing. With some basic maintenance your new bow will provide you with years of good shooting and dependable service.



*543 North Neil Armstrong Road
Salt Lake City, Utah 84116-2887
(801) 363-2990 phone
(801) 537-1470 fax
www.hoyt.com*

BOW OWNER'S PERSONAL RECORD

Fill in the following Personal Bow Record for your later reference.

Bow Serial Number _____

See page 26 for information on where your bow serial number is located.

Hoyt Bow Model _____

Purchased From _____

Purchase Date _____

Draw Length _____ " Draw Weight _____ #

String Length _____ " Buss Cable Length _____ "

Control Cable Length _____ "

Important Notes:

Save your sales receipt and serial number for your bow. The sales receipt, as well as your serial number, is your proof of date-of-purchase. **Proof of date-of-purchase will be required should your bow ever need warranty service.** The following space has been reserved for you to staple or tape your sales receipt for safe and convenient keeping.

IMPORTANT!

Staple or tape your sales receipt here for safekeeping.

COMPOUND BOW TERMINOLOGY

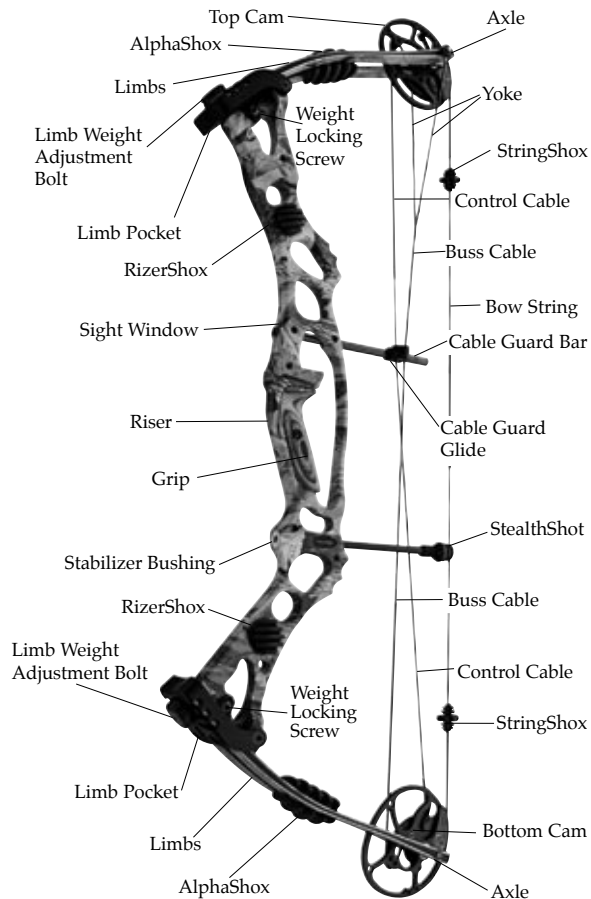

WARNING!
YOU'RE RESPONSIBLE FOR ARCHERY SAFETY

Please read the following safety information. Disregarding these rules may cause serious injury to yourself, others, or property.

1. NEVER "DRY FIRE" YOUR BOW. Dry fire means to draw and release the bowstring without an arrow. Firing a bow without an arrow to absorb the energy can cause severe damage to your bow and possible injury to the shooter or others nearby. Let-down the bow slowly and carefully from any drawn position.

2. NEVER EXPOSE YOUR BOW TO EXTREME HEAT OR PROLONGED EXTREME DAMP. Excessive heat, such as that experienced on a sunny day inside a closed vehicle, could cause limb failure. Prolonged storage in a hot dry attic or damp basement could also be damaging. Store the bow properly when it is not in use.

3. CAREFULLY INSPECT YOUR BOW BEFORE EACH USE. Carefully note the condition of the bowstring, limbs and riser before you shoot. Frayed bowstrings should be replaced. Damaged or suspect limbs should be reported to your local dealer for inspection or replacement.

4. BE SURE OF YOUR BACKSTOP. Make sure that the backstop you use is large enough to catch a stray arrow and that it is thick enough that the arrow cannot completely penetrate it. Make sure that it is positioned in a safe direction away from dwellings and other people.

5. BE SURE OF YOUR TARGET. Make sure that there are no persons, livestock, buildings or other objects behind or near your target. Be absolutely sure of your target in low light conditions.

6. INSPECT ALL ARROWS. Before shooting, inspect your arrows for defects. Discard cracked or dented shafts. Replace damaged or loose fletching and nocks.

7. ALWAYS BE SAFE. Never shoot straight up. Wear safety glasses when working on and shooting your bow. Be careful around strings and cables when using broadheads. Cutting strings and cables can cause serious damage to your bow and possible injury to you or others. Do not draw the bow beyond its maximum draw length. Never point or aim a drawn bow at another person. Children **must** be supervised by an adult.

8. READ AND HEED ALL WARNINGS. Hoyt cannot be held responsible for injuries suffered or caused by misuse, unsafe or improper arrow and bow combinations. Hoyt cannot be held responsible for injuries sustained when using an altered or modified Hoyt bow.

WARNING

This bow is a deadly weapon.

**Always abide by all safety advisements.
Children must be supervised by an adult.**

COMPOUND BOW MAINTENANCE

Your bow is a mechanical device and as such, is subject to wear and need of periodic inspection, adjustment and service. Hoyt recommends that you take your bow to a Hoyt authorized pro shop at least once a year for a yearly professional maintenance and inspection. Areas to be inspected are axles, spacers, lubrication of axle bushings (Hoyt Cam & 1/2 System bows are equipped with sealed ball bearings and do not require axle bushing lubrication), e-clips, strings, cables, limbs and riser.

The following information provides helpful instruction on the proper care and maintenance of your new Hoyt bow. Keep this manual as a handy guide for future reference.

STRINGS AND CABLES

Apply a light coat of bowstring wax to your bow's cables and string on a regular basis. Hoyt suggests once every two weeks during peak use. Use a high quality bowstring wax available at your local Hoyt pro shop. This will keep your bow's strings and cables in good condition. To assure best results replace your string and cables when wear is evident or every two years under normal use conditions.

Insist that Hoyt string and cables be used on your bow. Some Hoyt bow models come equipped with the FUSE Custom String System. In those cases, always replace your strings with FUSE brand strings. Beware of lesser quality string and cables as they may alter the performance of your bow or cause damage to it.

ECCENTRIC LUBRICATION

Cam & 1/2 System bows (except for Versa Cam & 1/2) feature sealed ball bearings which do not require lubrication.

For conventional bearings or bushings, a light spot lubrication of the axles where they pass through the eccentric should be done on a regular basis (1,500 - 2,000 shots). In adverse hunting conditions where dirt, dust or moisture are encountered, lubrication may be done on a daily basis. Hoyt recommends you use a silicone or Teflon based lubrication or any other quality grease available at your local Hoyt Pro Shop. It is not recommended that you use "Penetrating Oils" such as WD-40, EZ-#7, Fast Break, etc.

BOW PRESS USE

Never allow your bow to be put into a bow press unless it is operated by a knowledgeable bow technician. Hoyt recommends that all necessary adjustments requiring the use of a bow press be done by an authorized Hoyt pro shop.

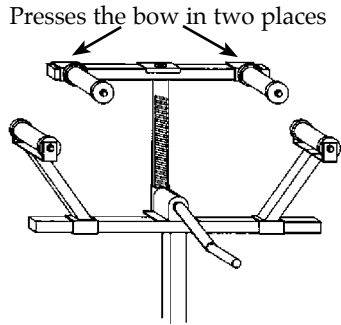

fig 1 (An Example of a Double Pull Bow Press)

Always use a double bow press like that shown in figure 1 when working on your bow. **Never use a single pull bow press.** (See fig 2)

Presses the bow at the grip only

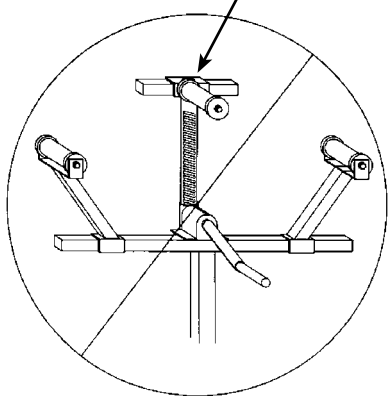

fig 2 (An Example of a Single Pull Bow Press)

Before putting your bow in a bow press, loosen both the top and bottom weight lock screws and weight adjustment bolts 5 to 7 turns from maximum weight (when limb bolts are fastened all the way down). When putting your bow in the press, **never put pressure on the riser!** Always position the rollers at the base of the limbs (where the limbs enter the limb pockets). (See fig 3)

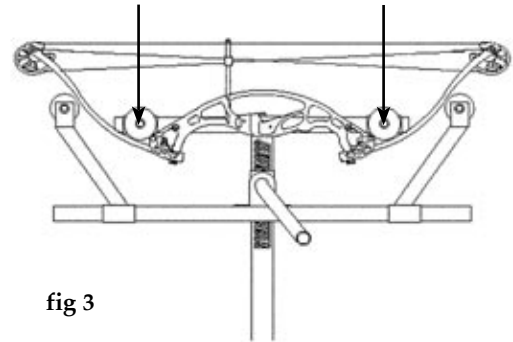

fig 3

COMPOUND BOW SETUP

REST SELECTION

There are three basic types of arrow rests: Shoot Through, Fall Away, and Shoot Around. Hoyt recommends that you seek the advice of a qualified pro shop for the proper rest selection for your style of shooting.

NOCK SET INSTALLATION

A nock point is a reference on the string that marks the exact location for you to nock your arrow. The arrow's nock is positioned under the nock set. To install the nock set at the proper position begin by slipping the nock set on the string. Then, using your rest as a reference, position the nock set just above level. A finger shooter should initially position the nock set at approximately 3/16" above level. The release shooter should position the nock set so that the arrow sits at a 90 degree angle with the string and adjust height as needed. (See fig 4) Once the nock set is at the desired location use a special set of nocking pliers to crimp the nock set into place. **NEVER** shoot a bow without a nock set or with a nock set that has not been properly crimped. For proper installation Hoyt recommends that this be done by a qualified pro shop.

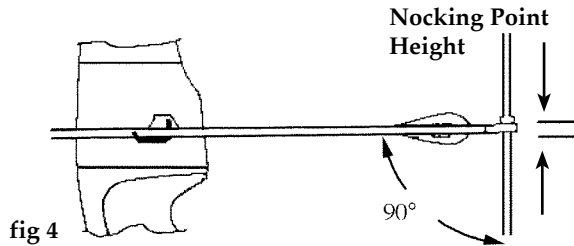

CABLE GUARD INSTALLATION

All Hoyt bows are designed with a built in cable guard bar attachment. Before mounting the cable guard bar, you must remove the rubberbands used only for shipping purposes. To insert the cable guard bar, simply slide the bar through the two mounting holes on the riser making sure that the bar is pushed completely through and flush with the end of the front mounting hole. After the bar has been inserted fasten with the 1/4-20 x 1/2" set screws provided. (See fig 5)

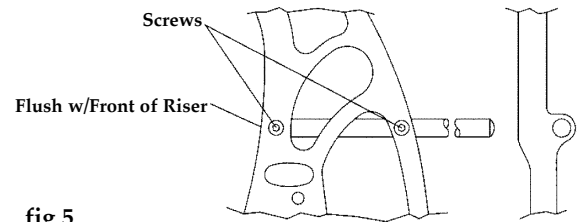
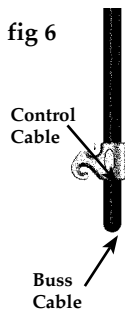

fig 5

CABLE GUARD GLIDE INSTALLATION

To prevent your bow's cables from rubbing against each other, Hoyt uses a specially designed cable glide that has off-set cable slots. To correctly install the glide on all Hoyt bows, first place the glide on the cable guard bar. (See fig 6) Next, push the control cable into the shorter front slot. Then, push the buss cable into the longer rear slot. **CAUTION: Do not pull bow back**

fig 6



without proper installation of cable guard bar and glide.

TILLER ADJUSTMENT

Tiller is the difference in distance between the upper limb to the string and lower limb to the string measured from the base of the limbs (where the limb and riser meet) at a 90 degree angle to the string.

(See fig 6)

The main function of tiller is to allow the archer to more easily and comfortably aim during the draw and release of the shot. Most bows will shoot best near even tiller which means the distance from the string to the limb is the same on top and bottom. Tiller adjustments are made by adjusting either limb weight adjustment bolt. (See draw weight adjustment section pg. 14) Example: If you have too

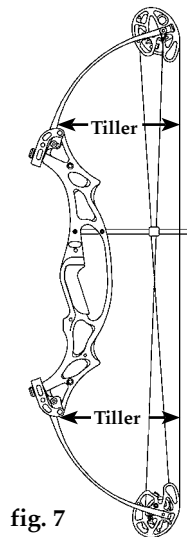

fig. 7

much tiller on the bottom limb, decrease the weight on the top limb or increase the weight on the bottom. Hoyt recommends that you initially set tiller equal top and bottom.

CENTERSHOT

Centershot is the alignment of the arrow in the power path of the string. This is accomplished by moving the arrow rest left or right. Release shooters should line the arrow up with or just slightly outside of the power path of the string. (See fig 8) Finger shooters should position the arrow so that the tip is just to the outside of the power path of the string. (See fig 8)

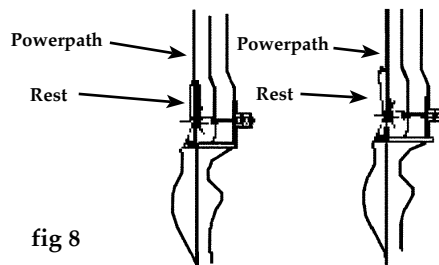

fig 8

Release Setting

Fingers Setting

Centershot is critical to how accurately a bow will perform. These are initial centershot settings, for proper alignment Hoyt recommends this be done by a qualified pro shop.

FLETCH CLEARANCE

Fletch clearance is the ability of your vanes or fletchings to pass cleanly by or through your arrow rest without impacting the rest so severely that the arrow's flight path is disrupted. It is necessary that you have adequate vane clearance to achieve proper arrow flight. (See fig 9)

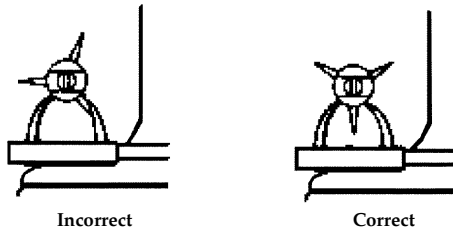

fig. 9

COMPOUND BOW ADJUSTMENT

DRAW WEIGHT ADJUSTMENT

Weight adjustments can easily be made by turning the weight adjustment bolt clockwise to increase weight or counter clockwise to decrease weight. Note: Always turn the top and bottom adjustment bolts in equal amounts. Some Hoyt model bows are equipped with a Dual Locking Pocket System. Before draw weight adjustments are made on these models you must first loosen the pocket locking screws located on both sides of the pocket. (Fig 10) When adjustments are complete, re-tighten screws.



StealthShot String Suppression System

The StealthShot is a highly effective noise and vibration dampening system. For optimum performance, make sure the StealthShot's Navcom dampener is **just barely** touching the string at brace height. **Note:** It **should not** have any pressure applied to it at brace height.

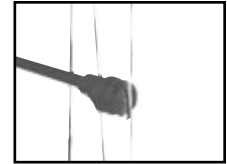

CAM & 1/2 DRAW LENGTH ADJUSTMENT

TOP CAM: To adjust the draw length on Hoyt's Cam & 1/2 (inner-cam) model bows, use a standard allen key to loosen the fastening screw and to remove the draw length screw. (see fig 11) Rotating the inner-cam in the (+) direction will lengthen the draw. Rotating the inner-cam in the (-) direction will shorten the draw. Each lettered position will provide approximately 1/2 inch longer / shorter draw than the previous setting. Once the inner-cam is in the desired location, reinstall and tighten

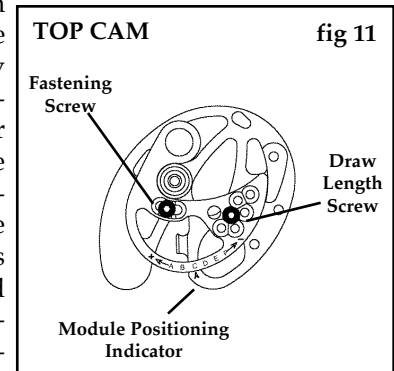

en the draw length screw first and then the fastening screw.

BOTTOM CAM: Remove the draw length screw, rotate module to the same lettered position as the top module, and replace. (see fig 12) **Note:** You must make the same adjustments to the top and the bottom inner-cams or the bow will not tune properly.

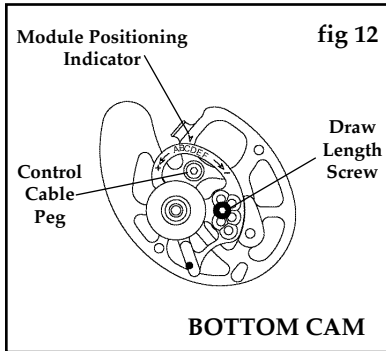

WARNING: Never remove the stainless steel control cable peg unless the string is relaxed in a bow press.

OPTIMIZING CAM & 1/2 PERFORMANCE

In order to verify the factory setting of your adjustable Cam & 1/2 System bow you should examine the cam's built-in reference holes. When viewing the module side of the top cam, at least part of the control cable should lie over the reference hole (see fig13). When viewing the module side of the bottom cam, at least part of the buss cable should lie over the reference hole as shown in fig 14. It is not necessary to have the cables centered over the reference holes. Module posi-

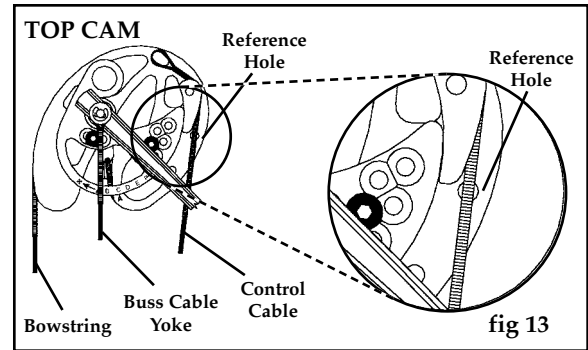

tion will not affect the reference hole location. Due to various limb configurations, some 2005 and later models are optimized with the cables slightly off the reference holes. In these cases, mark the cable locations on the cam (as shipped from the factory) with permanent ink. Use these marks for future reference. The factory tune is always optimized for performance.

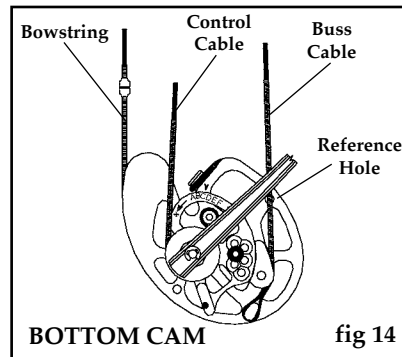

Zephyr Cam & 1/2

Hoyt's Zephyr Cam & 1/2 is a high performance draw length specific cam system. Cams are available in 1/2 inch draw-length increments. Zephyr cams are also available in either 65% or 80% ATA let-off. Both top and bottom cams must be swapped out to change the bow's let-off.

Adjustable Valley Technology (AVT)

The Zephyr Cam & 1/2 features AVT, which allows the shooter to customize how the cam feels at full draw. An optional draw stop peg is included. Without the peg the back wall is softest and the cam will have the longest valley. With the draw stop installed in the furthest outboard position the cam will feature a long valley and a hard wall. In the inboard peg position the cam has a hard wall and a shorter valley. The draw length and let-off are essentially the same with or without the AVT draw-stop peg installed. (See fig 15)

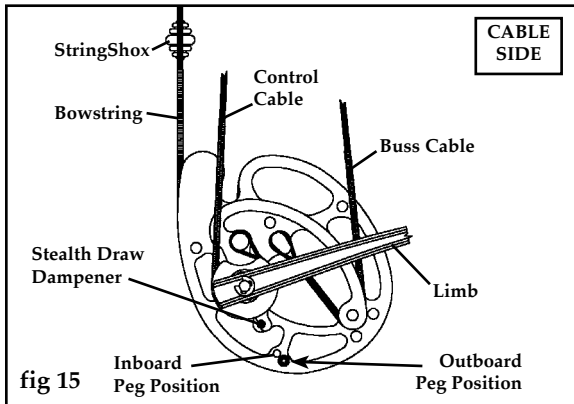

18

Zephyr Cam & 1/2 Optimization

Zephyr Cam & 1/2 features performance marks on the bottom cam to indicate the optimum performance range for the cam. The limb should lie somewhere between the lines when the bottom cam is viewed from the logo side at brace. (See fig 16) In some cases the limb will not be exactly centered. This is by design since each individual cam/limb combination is factory optimized for performance and draw length. If draw length adjustments are necessary, it is acceptable to shorten strings or cables. You will retain excellent performance from your Zephyr Cam & 1/2 as long as the limb lies anywhere within the performance marks.

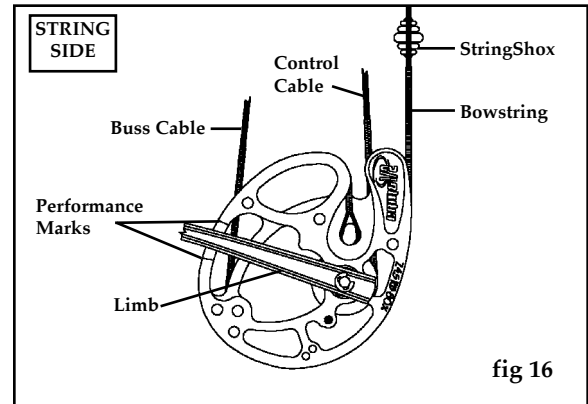
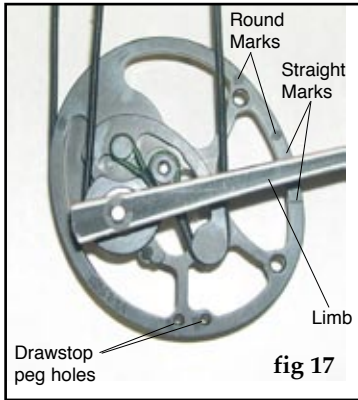

fig 16

VECTOR and C2 CAM & 1/2 Performance Systems

To verify proper cam orientation on bows featuring Hoyt's Vector and C2 Cam & 1/2 Systems, you should examine the cams' built-in performance marks on the bottom cam. There are two different sets of performance marks engraved on all



bottom cams. One set is a circle with a line through it (round mark) and the other is a line only (straight mark). On some cam sizes, one of the straight marks actually lies on one of the round marks, creating a circle with two lines through it. Your individual bow model will determine which set of marks you will reference. To verify that the Vector cam on the 38 Ultra is in the proper position, be sure the limb lies between the round marks on the cam. For the Vectrix, Vectrix XL and Vulcan, the limb should lie between the two straight marks (see figure 17). On bows equipped with C2 cam and XT 2000 or XT 3000 limbs, use the straight marks for reference and on bows equipped with C2 cams and XT 3500 limbs use the round marks. On both C2 and Vector cam, the limb should lie somewhere between the marks but does not need to be centered.

Vector cams provide 75% let-off and a softer wall when the drawstop peg is not installed. Installing the peg into the 75% let-off hole (see figure 17) will maintain the 75% let-off but provide a harder wall. To change the let-off to 65%, move the let-off peg to the 65% let-off location and add 2 or 3 twists to the buss cable to maintain optimum cam synchronization at full draw (visit your authorized Hoyt dealer for assistance). C2 cam is only available in low let-off. Installing the drawstop peg will provide a harder wall.

WHEEL & 1/2 DRAW LENGTH & OPTIMIZATION

Hoyt's Wheel & 1/2 system is shipped as a draw length specific pair of eccentrics with an optional draw stop. You may alter string and cable lengths as needed to achieve your exact draw specifications.

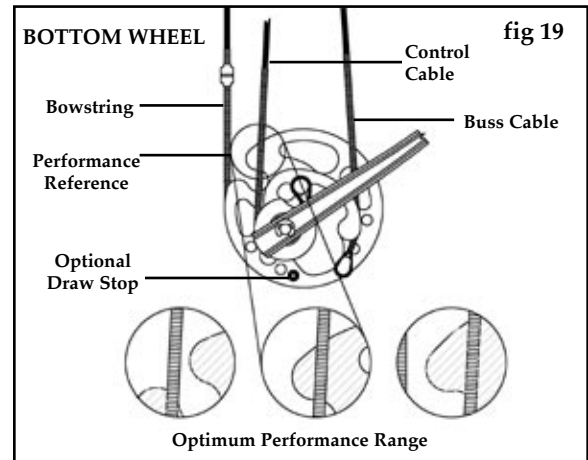

However, excess string or cable twists will alter the peak draw weight and may reduce the performance of the wheels on your bow. Hoyt recommends staying within the optimum performance range shown in Figure 19. If your draw length requires a cam position well outside the range shown in Figure 20, you may consider changing to a smaller or larger cam as needed. Please consult your local authorized Hoyt dealer. Start by setting the bottom wheel position as shown in Figure 19. Next, approximately match the distance on the top and bottom wheels between the bowstring and the point of the wheels as shown in Figure 20. (You may need to change the control cable length to optimize the top wheel position.) Exact measurements are not necessary since the Wheel & 1/2 system is not sensitive to timing and synchronization.

fig 20

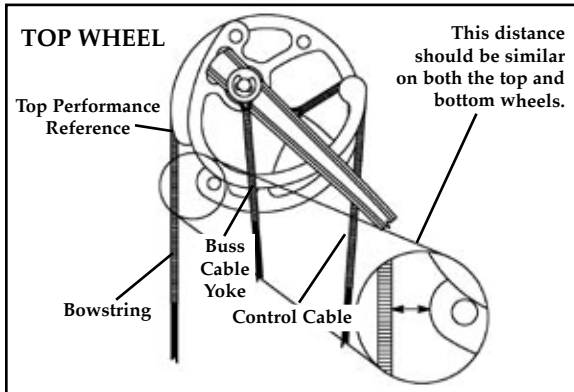

WHEEL & 1/2 OPTIONAL DRAW STOP

The draw stop on the Wheel & 1/2 system can be utilized to customize the feel of the back wall. If you prefer a hard wall, install the peg in the threaded 6-32 hole in the bottom cam as shown in Figure 19. If you prefer a softer wall and more of a "valley," shoot the wheel without the draw stop installed. The use of any non-Hoyt draw stop will void the product warranty and may damage the product.

VERSA CAM & 1/2 DRAW LENGTH ADJUSTMENT

Hoyt's youth cam, the Versa Cam & 1/2 System, features a patented inner-cam draw length adjustment that does not require the use of a bow press. To adjust the draw length, start by removing the draw length screw and the module fastening screw from the bottom cam. Rotate the module until the draw

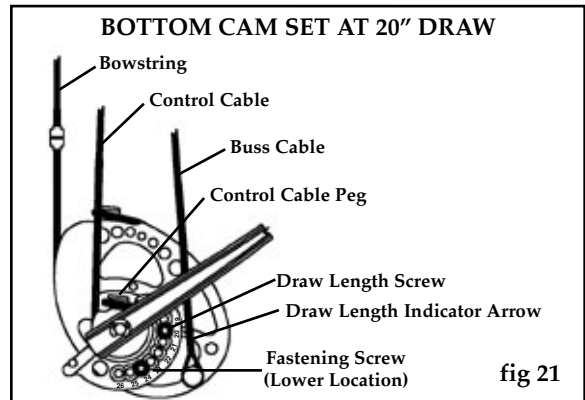

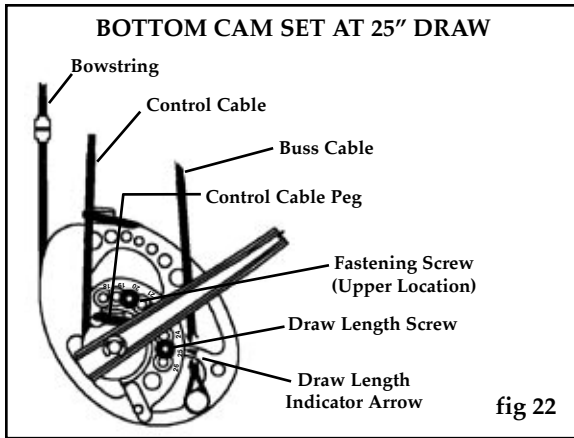

length indicator arrow on the cam aligns with the desired draw length scribed on the module (Figure 21). Reinstall both screws and re-tighten. Note that at draw lengths between 18 and 22 inches the lower fastening screw location will be utilized (Figure 21), while draw between 23 and 26 inches utilize the upper module fastening screw location (Figure 22). Always be sure to install and tighten both module screws prior to drawing or shooting the bow to prevent damage to the product.

After the bottom cam draw length is adjusted, repeat the procedure on the top wheel by loosening the fastening screw and removing the draw length screw. Rotate the module to the SAME draw length position as the bottom module and replace and tighten both

the draw length screw and the module fastening screw. Note that the draw length of the top cam is indicated by the number closest to the draw length screw (Figure 23). Ensure both screws are installed and tightened prior to drawing or shooting the bow to prevent damaging the product.

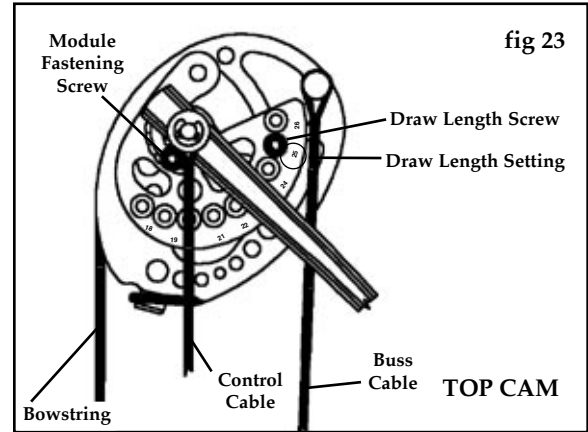

VERSA CAM & 1/2 CONTROL CABLE REMOVAL

To remove the control cable from the bottom cam, the bottom module must be rotated to a draw length of 20 inches or less. Failure to move the module prior to installation or removal of the lower control cable loop may result in damage to the string fibers and premature cable failure.

LOCATING YOUR BOW'S SERIAL NUMBER

The seven-digit serial number on all aluminum Hoyt compound bows is located on the riser between the top limbs and under the pocket. (See fig 24) To find the serial number on magnesium bows, look at the rest mount surface. (See fig 25) If you have already attached a rest to your riser, you may have to remove it to see the serial number.

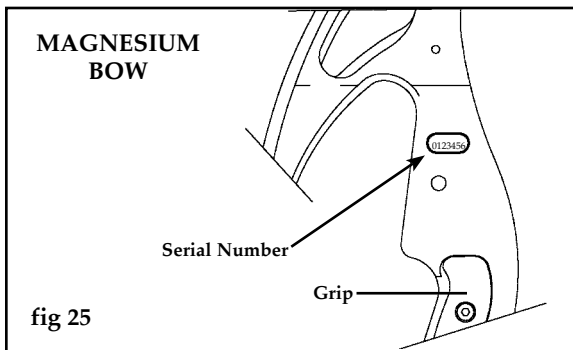
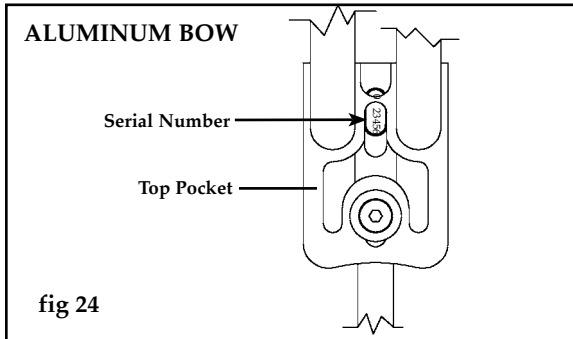

TUNING YOUR BOW

There are numerous methods you can use when tuning your Hoyt bow. Hoyt recommends working closely with your local pro shop when tuning your bow to ensure best results. For detailed tuning information, download Easton's tuning guide at www.eastonarchery.com/downloads.

BROADHEADS

Most archers discover that they must make slight tuning adjustments when switching from practice points to broadheads (even at the same weight). Broadheads create a dramatic aerodynamic change in arrow flight. For this reason, slight adjustments may need to be made in nocking point height, rest position or bow weight to achieve desired broadhead flight. Always test shoot broadheads before hunting to ensure proper sight settings. Even expandable broadheads may require different sight settings than field points.

HOYT COMPOUND BOW WARRANTY

All Hoyt compound bows are warranted against defects in materials or workmanship to **the original owner** on all risers, limbs, limb pockets, and eccentrics for the life of the product.

ACCESSORIES

All Hoyt sights (excluding sight pins), arrow rests, and bow quivers (excluding hood foam and arrow gripper) are warranted 100% for the life of the product to the original owner. Hoyt must perform warranty work.

You must have the following items in order to obtain warranty work:

1. A dated proof of purchase (sales receipt).
2. Products must be purchased through a Hoyt authorized dealer (no exceptions!)
3. All compound bows must have a serial number. (See page 26 for information on serial number location)

Buying a Hoyt bow over the Internet voids all warranty.

Hoyt, at its discretion, voids all warranty claims either expressed or implied including but not limited to evidence of abuse, modification to original design, use of attachments or accessories that cause excessive stress.

Hoyt reserves the right to make substitutions on warranty coverage at Hoyt's discretion for any reason. **Warranty is subject to available parts.**

OBTAINING WARRANTY SERVICE

To obtain warranty service, you should return your bow to the pro shop where you purchased your Hoyt bow. The dealer can help to determine if Hoyt factory service is required or if the repair can be completed by the pro shop. If the bow must be returned to the factory, the bow owner is responsible for the freight charges to Hoyt. Hoyt, in turn, will pay for the same return freight of the repaired product.

Before any bow is returned a **Return Authorization Number** must be obtained through an authorized Hoyt pro shop. Bows returned to the factory without a Return Authorization number will be sent back. Do not send accessories with bow unless otherwise instructed to.

Write the RA number on the outside of the shipping box and send the Hoyt bow requiring factory service to:

Hoyt
543 N. Neil Armstrong Road
Salt Lake City, UT 84116

There are no other warranties expressed or implied that extend beyond those written here. No agent, employee or representative of Hoyt or its dealers has the authority to bind Hoyt to any agreement not herein stated. Buyer agrees that the sole and exclusive remedies for breach on any warranty concerning Hoyt bows shall be repair or replacement of defective parts. Hoyt shall not be liable for injury or property other than the bows themselves. Hoyt reserves the right to replace defective parts according to availability with compatible replacement parts.